

TRAFFIC CRASH REPORT

*DENOTES MANDATORY FIELD FOR SUPPLEMENT REPORT

LOCAL REPORT NUMBER*

24-OPD-0364

PHOTOS TAKEN
 SECONDARY CRASH
 PRIVATE PROPERTY

LOCAL INFORMATION
 REPORTING AGENCY NAME* City of Oxford Police Dept. NCIC* 09070

HIT/SKIP
 1 - SOLVED
 2 - UNSOLVED

NUMBER OF UNITS
02

UNIT IN ERROR
 98 - ANIMAL
 99 - UNKNOWN
01

COUNTY* 09 LOCALITY* 1
 1 - CITY
 2 - VILLAGE
 3 - TOWNSHIP

LOCATION: CITY, VILLAGE, TOWNSHIP*
Oxford

CRASH DATE / TIME*
03132924 1130

CRASH SEVERITY
 1 - FATAL
 2 - SERIOUS INJURY SUSPECTED
 3 - MINOR INJURY SUSPECTED
 4 - INJURY POSSIBLE
 5 - PROPERTY DAMAGE ONLY
5

ROUTE TYPE
2
 1 - NORTH
 2 - SOUTH
 3 - EAST
 4 - WEST

LOCATION ROAD NAME
Campus

LATITUDE DECIMAL DEGREES
39.508355

ROAD TYPE
AV

ROUTE TYPE
3
 1 - NORTH
 2 - SOUTH
 3 - EAST
 4 - WEST

REFERENCE ROAD NAME (ROAD, MILEPOST, HOUSE #)
Collins

LONGITUDE DECIMAL DEGREES
-84.739317

ROAD TYPE
ST

REFERENCE POINT
 1 - INTERSECTION
 2 - MILE POST
 3 - HOUSE #
1

ROUTE TYPE
 IR - INTERSTATE ROUTE (TP)
 US - FEDERAL US ROUTE
 SR - STATE ROUTE
 CR - NUMBERED COUNTY ROUTE
 TR - NUMBERED TOWNSHIP ROUTE

INTERSECTION RELATED
 WITHIN INTERSECTION OR ON APPROACH
 WITHIN INTERCHANGE AREA
 NUMBER OF APPROACHES

DIRECTION FROM REFERENCE
4
 1 - NORTH
 2 - SOUTH
 3 - EAST
 4 - WEST

ROAD TYPE
 AL - ALLEY
 AV - AVENUE
 BL - BOULEVARD
 CR - CIRCLE
 CT - COURT
 DR - DRIVE
 HE - HEIGHTS
 HW - HIGHWAY
 LA - LANE
 MP - MILEPOST
 OV - OVAL
 PK - PARKWAY
 PI - PIKE
 PL - PLACE
 RD - ROAD
 SQ - SQUARE
 ST - STREET
 TE - TERRACE
 TL - TRAIL
 WA - WAY

ROADWAY
 ROADWAY DIVIDED

LOCATION OF FIRST HARMFUL EVENT
 1 - ON ROADWAY
 2 - ON SHOULDER
 3 - IN MEDIAN
 4 - ON ROADSIDE
 5 - ON GORE
 6 - OUTSIDE TRAFFIC WAY
 7 - ON RAMP
 8 - OFF RAMP
01

MANNER OF CRASH COLLISION / IMPACT
 1 - NOT COLLISION BETWEEN TWO MOTOR VEHICLES IN TRANSPORT
 2 - REAR-END
 3 - HEAD-ON
 4 - REAR-TO-REAR
 5 - BACKING
 6 - ANGLE
 7 - SIDESWIPE, SAME DIRECTION
 8 - SIDESWIPE, OPPOSITE DIRECTION
 9 - OTHER / UNKNOWN
6

DIRECTION OF TRAVEL
 1 - NORTH
 2 - SOUTH
 3 - EAST
 4 - WEST

MEDIAN TYPE
 1 - DIVIDED FLUSH MEDIAN (<4 FEET)
 2 - DIVIDED FLUSH MEDIAN (>4 FEET)
 3 - DIVIDED DEPRESSED MEDIAN (ANY TYPE)
 4 - DIVIDED RAISED MEDIAN (ANY TYPE)
 9 - OTHER / UNKNOWN

WORK ZONE RELATED
 WORKERS PRESENT
 LAW ENFORCEMENT PRESENT
 ACTIVE SCHOOL ZONE

WORK ZONE TYPE
 1 - LANE CLOSURE
 2 - LANE SHIFT/CROSSOVER
 3 - WORK ON SHOULDER OR MEDIAN
 4 - INTERMITTENT OR MOVING WORK
 5 - OTHER

LOCATION OF CRASH IN WORK ZONE
 1 - BEFORE THE 1ST WORK ZONE WARNING SIGN
 2 - ADVANCE WARNING AREA
 3 - TRANSITION AREA
 4 - ACTIVITY AREA
 5 - TERMINATION AREA

CONTOUR
1
 1 - STRAIGHT LEVEL
 2 - STRAIGHT GRADE
 3 - CURVE LEVEL
 4 - CURVE GRADE
 9 - OTHER/UNKNOWN

CONDITIONS
9
 1 - DRY
 2 - WET
 3 - SNOW
 4 - ICE
 5 - SAND, MUD, DIRT, OIL, GRAVEL
 6 - WATER (STANDING, MOVING)
 7 - SLUSH
 9 - OTHER / UNKNOWN

SURFACE
2
 1 - CONCRETE
 2 - BLACKTOP, BITUMINOUS, ASPHALT
 3 - BRICK / BLOCK
 4 - SLAG, GRAVEL, STONE
 5 - DIRT
 9 - OTHER/UNKNOWN

LIGHT CONDITION
1
 1 - DAYLIGHT
 2 - DAWN / DUSK
 3 - DARK - LIGHTED ROADWAY
 4 - DARK - ROADWAY NOT LIGHTED
 5 - DARK - UNKNOWN ROADWAY LIGHTING
 9 - OTHER / UNKNOWN

WEATHER
99
 1 - CLEAR
 2 - CLOUDY
 3 - FOG, SMOG, SMOKE
 4 - RAIN
 5 - SLEET, HAIL
 6 - SNOW
 7 - SEVERE CROSSWINDS
 8 - BLOWING SAND, SOIL, DIRT, SNOW
 9 - FREEZING RAIN OR FREEZING DRIZZLE
 99 - OTHER / UNKNOWN

WEATHER
 6 - SNOW
 7 - SEVERE CROSSWINDS
 8 - BLOWING SAND, SOIL, DIRT, SNOW
 9 - FREEZING RAIN OR FREEZING DRIZZLE
 99 - OTHER / UNKNOWN

CONTOUR
 1 - STRAIGHT LEVEL
 2 - STRAIGHT GRADE
 3 - CURVE LEVEL
 4 - CURVE GRADE
 9 - OTHER/UNKNOWN

CONDITIONS
 1 - DRY
 2 - WET
 3 - SNOW
 4 - ICE
 5 - SAND, MUD, DIRT, OIL, GRAVEL
 6 - WATER (STANDING, MOVING)
 7 - SLUSH
 9 - OTHER / UNKNOWN

SURFACE
 1 - CONCRETE
 2 - BLACKTOP, BITUMINOUS, ASPHALT
 3 - BRICK / BLOCK
 4 - SLAG, GRAVEL, STONE
 5 - DIRT
 9 - OTHER/UNKNOWN

NARRATIVE
 Unit 2 was traveling north on S. Campus Avenue. Unit 2 made a left hand turn onto E. Collins St. Unit 1 was at the intersection of E. Collins St. and S. Campus Ave. Unit 1 failed to yield and made a left hand turn onto S. Campus Ave. Striking Unit 2.

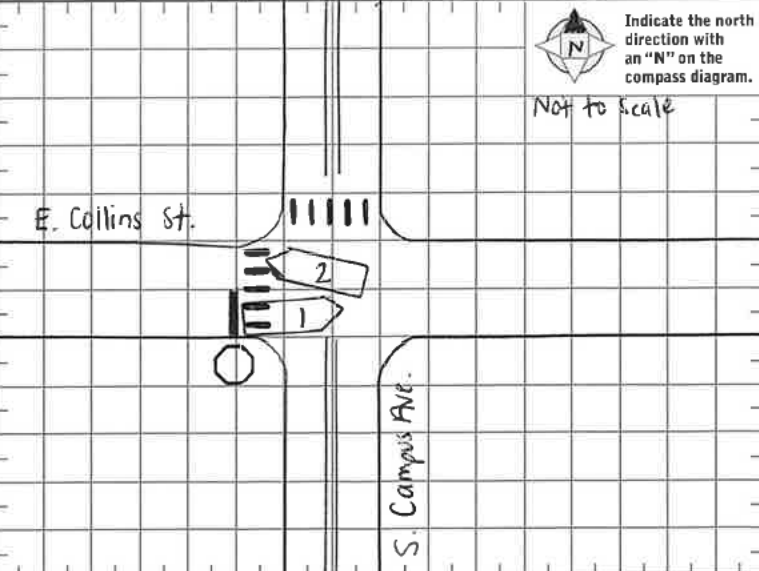

CRASH REPORTED DATE / TIME
04222024 1915

DISPATCH DATE / TIME
04222024 1918

ARRIVAL DATE / TIME
04222024 1923

SCENE CLEARED DATE / TIME
04222024 2000

REPORT TAKEN BY
 POLICE AGENCY
 MOTORIST

TOTAL TIME ROADWAY CLOSED
0

OTHER INVESTIGATION TIME
90

TOTAL MINUTES
132

OFFICER'S NAME*
Ptl. B. Hartwig
 OFFICER'S BADGE NUMBER*
57

CHECKED BY OFFICER'S NAME*
Sgt M Hatfield
 CHECKED BY OFFICER'S BADGE NUMBER*
35

SUPPLEMENT (CORRECTION OR ADDITION TO AN EXISTING REPORT SENT TO THE OHIO DEPARTMENT OF PUBLIC SAFETY)

LOCAL REPORT NUMBER
24-OPD-0364

OWNER

UNIT # 01 OWNER NAME: LAST, FIRST, MIDDLE (SAME AS DRIVER) Lishing, Carl, M.
 OWNER ADDRESS: STREET, CITY, STATE, ZIP (SAME AS DRIVER) 10009 Edgewater Dr. Cleveland, OH 44102
 COMMERCIAL CARRIER: NAME, ADDRESS, CITY, STATE, ZIP _____ COMMERCIAL CARRIER PHONE: (INCLUDE AREA CODE) _____

DAMAGE

DAMAGE SCALE
2 1 - NONE 3 - FUNCTIONAL DAMAGE
 2 - MINOR DAMAGE 4 - DISABLING DAMAGE
 9 - UNKNOWN

VEHICLE

LP STATE OH LICENSE PLATE # HED9626 VEHICLE IDENTIFICATION # 29XFB2F57CE060324 VEHICLE YEAR 2012 VEHICLE MAKE Honda
 INSURANCE VERIFIED Safeco Insurance INSURANCE POLICY # K2954027 COLOR Light Blue VEHICLE MODEL Civic
 COMMERCIAL GOVERNMENT IN EMERGENCY RESPONSE US DOT # _____ TOWED BY: COMPANY NAME _____
 INTERLOCK DEVICE EQUIPPED HIT/SKIP UNIT # 03 VEHICLE WEIGHT GVWR/GCWR: 1 - <10K LBS. 2 - 10,001 - 26K LBS. 3 - >26K LBS. MATERIAL CLASS # _____ PLACARD ID # _____

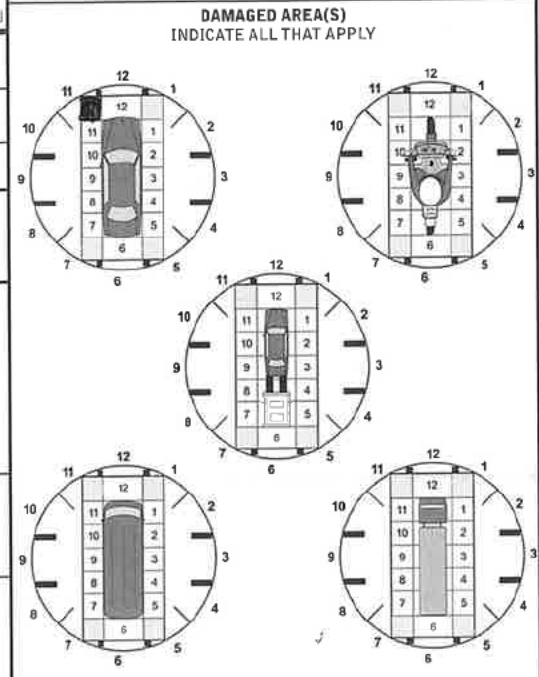

UNIT TYPE 01 # OF TRAILING UNITS 0

1 - PASSENGER CAR	7 - MOTORCYCLE 2-WHEELED	12 - GOLF CART	18 - LIMO (LIVERY VEHICLE)	23 - PEDESTRIAN / SKATER
2 - PASSENGER VAN (MINIVAN)	8 - MOTORCYCLE 3-WHEELED	13 - SNOWMOBILE	19 - BUS (16+ PASSENGERS)	24 - WHEELCHAIR (ANYTYPE)
3 - SPORT UTILITY VEHICLE	9 - AUTOCYCLE	14 - SINGLE UNIT TRUCK	20 - OTHER VEHICLE	25 - OTHER NON-MOTORIST
4 - PICK UP	10 - MOPEL OR MOTORIZED BICYCLE	15 - SEMI-TRACTOR	21 - HEAVY EQUIPMENT	26 - BICYCLE
5 - CARGO VAN	11 - ALL TERRAIN VEHICLE (ATV/UTV)	16 - FARM EQUIPMENT	22 - ANIMAL WITH RIDER OR ANIMAL-DRAWN VEHICLE	27 - TRAIN
6 - VAN (9-15 SEATS)		17 - MOTORHOME		99 - UNKNOWN OR HIT/SKIP

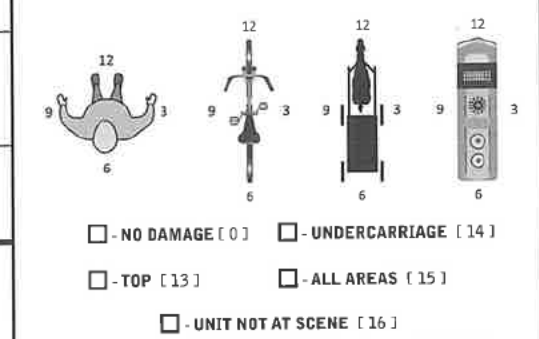

WAS VEHICLE OPERATING IN AUTONOMOUS MODE WHEN CRASH OCCURRED? 0 AUTONOMOUS MODE LEVEL

0 - NO AUTOMATION	3 - CONDITIONAL AUTOMATION	9 - UNKNOWN
1 - DRIVER ASSISTANCE	4 - HIGH AUTOMATION	
2 - PARTIAL AUTOMATION	5 - FULL AUTOMATION	

SPECIAL FUNCTION 01

1 - NONE	6 - BUS - CHARTER/TOUR	11 - FIRE	16 - FARM	21 - MAIL CARRIER
2 - TAXI	7 - BUS - INTERCITY	12 - MILITARY	17 - MOWING	99 - OTHER / UNKNOWN
3 - ELECTRONIC RIDE SHARING	8 - BUS - SHUTTLE	13 - POLICE	18 - SNOW REMOVAL	
4 - SCHOOL TRANSPORT	9 - BUS - OTHER	14 - PUBLIC UTILITY	19 - TOWING	
5 - BUS - TRANSIT/COMMUTER	10 - AMBULANCE	15 - CONSTRUCTION EQUIPMENT	20 - SAFETY SERVICE PATROL	

CARGO BODY TYPE 01

1 - NO CARGO BODY TYPE / NOT APPLICABLE	3 - VEHICLE TOWING ANOTHER MOTOR VEHICLE	5 - INTERMODAL CONTAINER CHASSIS	8 - POLE	12 - CONCRETE MIXER
2 - BUS	4 - LOGGING	6 - CARGO VAN/ENCLOSED BOX	9 - CARGOTANK	13 - AUTOTRANSPORTER
		7 - GRAIN/CHIPS/GRAVEL	10 - FLAT BED	14 - GARBAGE/REFUSE
			11 - DUMP	99 - OTHER / UNKNOWN

VEHICLE DEFECTS

1 - TURN SIGNALS	4 - BRAKES	7 - WORN OR SLICK TIRES	9 - MOTOR TROUBLE	99 - OTHER / UNKNOWN
2 - HEAD LAMPS	5 - STEERING	8 - TRAILER EQUIPMENT DEFECTIVE	10 - DISABLED FROM PRIOR ACCIDENT	
3 - TAIL LAMPS	6 - TIRE BLOWOUT			

NON-MOTORIST LOCATION AT IMPACT

1 - INTERSECTION - MARKED CROSSWALK	3 - INTERSECTION - OTHER	6 - BICYCLE LANE	9 - MEDIAN/CROSSING ISLAND	12 - FIRST RESPONDER AT INCIDENT SCENE
2 - INTERSECTION - UNMARKED CROSSWALK	4 - MIDBLOCK - MARKED CROSSWALK	7 - SHOULDER / ROADSIDE	10 - DRIVEWAY ACCESS	99 - OTHER / UNKNOWN
	5 - TRAVEL LANE - OTHER LOCATION	8 - SIDEWALK	11 - SHARED USE PATHS OR TRAILS	

ACTION 3 PRE-CRASH ACTIONS 06

1 - NON-CONTACT	1 - STRAIGHT AHEAD	7 - MAKING U-TURN	13 - NEGOTIATING A CURVE	18 - APPROACHING OR LEAVING VEHICLE
2 - NON-COLLISION	2 - BACKING	8 - ENTERING TRAFFIC LANE	14 - ENTERING OR CROSSING SPECIFIED LOCATION	19 - STANDING
3 - STRIKING	3 - CHANGING LANES	9 - LEAVING TRAFFIC LANE	15 - WALKING, RUNNING, JOGGING, PLAYING	20 - OTHER NON-MOTORIST
4 - STRUCK	4 - OVERTAKING/PASSING	10 - PARKED	16 - WORKING	21 - STANDING OUTSIDE DISABLED VEHICLE
5 - BOTH STRIKING & STRUCK	5 - MAKING RIGHT TURN	11 - SLOWING OR STOPPED IN TRAFFIC	17 - PUSHING VEHICLE	99 - OTHER / UNKNOWN
9 - OTHER / UNKNOWN	6 - MAKING LEFT TURN	12 - DRIVERLESS		

INITIAL POINT OF CONTACT

0 - NO DAMAGE	14 - UNDERCARRIAGE
1-12 - REFER TO UNIT DIAGRAM	15 - VEHICLE NOT AT SCENE
13 - TOP	99 - UNKNOWN

CONTRIBUTING CIRCUMSTANCES 02

1 - NONE	7 - LEFT OF CENTER	13 - IMPROPER START FROM A PARKED POSITION	17 - VISION OBSTRUCTION	21 - LYING IN ROADWAY
2 - FAILURE TO YIELD	8 - FOLLOWING TOO CLOSE / ACDA	14 - STOPPED OR PARKED ILLEGALLY	18 - OPERATING DEFECTIVE EQUIPMENT	22 - NOT DISCERNIBLE
3 - RAN RED LIGHT	9 - IMPROPER LANE CHANGE	15 - SWERVING TO AVOID	19 - LOAD SHIFTING/FALLING/ SPILLING	23 - OPENING DOOR INTO ROADWAY
4 - RAN STOP SIGN	10 - IMPROPER PASSING	16 - WRONG WAY	20 - IMPROPER CROSSING	99 - OTHER IMPROPER ACTION
5 - UNSAFE SPEED	11 - DROVE OFF ROAD			
6 - IMPROPER TURN	12 - IMPROPER BACKING			

TRAFFIC

TRAFFICWAY FLOW 1 - ONE-WAY 2 - TWO-WAY	TRAFFIC CONTROL 1 - ROUNDABOUT 4 - STOP SIGN 2 - SIGNAL 5 - YIELD SIGN 3 - FLASHER 6 - NO CONTROL
--	---

SEQUENCE OF EVENTS

1 <u>20</u> 1 - OVERTURN/ROLLOVER	6 - EQUIPMENT FAILURE	11 - CROSS CENTERLINE - OPPOSITE DIRECTION OF TRAVEL	16 - RAILWAY VEHICLE	22 - WORK ZONE MAINTENANCE EQUIPMENT
2 - FIRE/EXPLOSION	7 - SEPARATION OF UNITS	12 - DOWNHILL RUNAWAY	17 - ANIMAL - FARM	23 - STRUCK BY FALLING, SHIFTING CARGO OR ANYTHING SET IN MOTION BY A MOTOR VEHICLE
3 - IMMERSION	8 - RAN OFF ROAD RIGHT	13 - OTHER NON-COLLISION	18 - ANIMAL - DEER	24 - OTHER MOVABLE OBJECT
4 - JACKKNIFE	9 - RAN OFF ROAD LEFT	14 - PEDESTRIAN	19 - ANIMAL - OTHER	
5 - CARGO / EQUIPMENT LOSS OR SHIFT	10 - CROSS MEDIAN	15 - PEDALCYCLE	20 - MOTOR VEHICLE IN TRANSPORT	

OF THROUGH LANES ON ROAD 2

RAIL GRADE CROSSING 1

UNIT / NON-MOTORIST DIRECTION

FROM <u>3</u> TO <u>1</u>	1 - NORTH 5 - NORTHEAST 2 - SOUTH 6 - NORTHWEST 3 - EAST 7 - SOUTHEAST 4 - WEST 8 - SOUTHWEST 9 - OTHER / UNKNOWN
---------------------------	---

COLLISION WITH FIXED OBJECT - STRUCK

25 - IMPACT ATTENUATOR / CRASH CUSHION	31 - GUARDRAIL END	37 - TRAFFIC SIGN POST	43 - CURB	50 - WORK ZONE MAINTENANCE EQUIPMENT
26 - BRIDGE OVERHEAD STRUCTURE	32 - PORTABLE BARRIER	38 - OVERHEAD SIGN POST	44 - DITCH	51 - WALL
27 - BRIDGE PIER OR ABUTMENT	33 - MEDIAN CABLE BARRIER	39 - LIGHT / LUMINARIES SUPPORT	45 - EMBANKMENT	52 - BUILDING
28 - BRIDGE PARAPET	34 - MEDIAN GUARDRAIL BARRIER	40 - UTILITY POLE	46 - FENCE	53 - TUNNEL
29 - BRIDGE RAIL	35 - MEDIAN CONCRETE BARRIER	41 - OTHER POST, POLE OR SUPPORT	47 - MAILBOX	54 - OTHER FIXED OBJECT
30 - GUARDRAIL FACE	36 - MEDIAN OTHER BARRIER	42 - CULVERT	48 - TREE	99 - OTHER / UNKNOWN
			49 - FIRE HYDRANT	

FIRST HARMFUL EVENT 1 MOST HARMFUL EVENT 1

UNIT SPEED 5

POSTED SPEED 25

DETECTED SPEED 1

1 - STATED / ESTIMATED SPEED
2 - CALCULATED / EDR
3 - UNDETERMINED

OWNER
 UNIT # **02** OWNER NAME: LAST, FIRST, MIDDLE (SAME AS DRIVER) **Taylor, Theodore, A.**
 OWNER ADDRESS: STREET, CITY, STATE, ZIP (SAME AS DRIVER) **6149 Saint Regis Dr. Cincinnati, OH 45236**
 COMMERCIAL CARRIER: NAME, ADDRESS, CITY, STATE, ZIP
 OWNER PHONE: INCLUDE AREA CODE (SAME AS DRIVER) **[REDACTED]**
 COMMERCIAL CARRIER PHONE: INCLUDE AREA CODE

DAMAGE
DAMAGE SCALE
2 1 - NONE 3 - FUNCTIONAL DAMAGE
 2 - MINOR DAMAGE 4 - DISABLING DAMAGE
 9 - UNKNOWN

VEHICLE
 LP STATE **OH** LICENSE PLATE # **JUX3962** VEHICLE IDENTIFICATION # **WBAJV43598G260350** VEHICLE YEAR **2008** VEHICLE MAKE **BMW**
 INSURANCE VERIFIED INSURANCE COMPANY **State Farm** INSURANCE POLICY # **3163704-SFP-35** COLOR **Silver** VEHICLE MODEL **528x**
 COMMERCIAL GOVERNMENT IN EMERGENCY RESPONSE
 INTERLOCK DEVICE EQUIPPED HIT/SKIP UNIT #OCCUPANTS **01** VEHICLE WEIGHT GVWR/GCWR
 1 - ≤10K LBS.
 2 - 10,001 - 26K LBS.
 3 - >26K LBS.
 TOWED BY: COMPANY NAME
 HAZARDOUS MATERIAL
 MATERIAL RELEASED CLASS # PLACARD ID #
 PLACARD

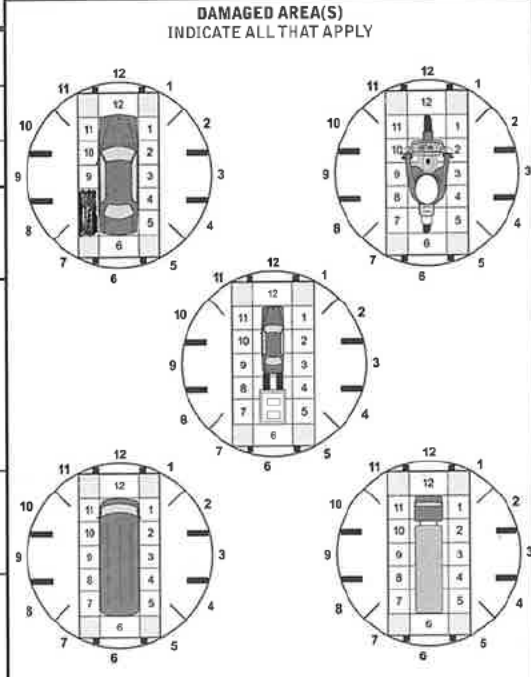

UNIT TYPE
01
 1 - PASSENGER CAR 7 - MOTORCYCLE 2-WHEELED 12 - GOLF CART 18 - LIMO (LIVERY VEHICLE) 23 - PEDESTRIAN / SKATER
 2 - PASSENGER VAN (MINIVAN) 8 - MOTORCYCLE 3-WHEELED 13 - SNOWMOBILE 19 - BUS (16+ PASSENGERS) 24 - WHEELCHAIR (ANY TYPE)
 3 - SPORT UTILITY VEHICLE 9 - AUTOCYCLE 14 - SINGLE UNIT TRUCK 20 - OTHER VEHICLE 25 - OTHER NON-MOTORIST
 4 - PICK UP 10 - MOPED OR MOTORIZED BICYCLE 15 - SEMI-TRACTOR 21 - HEAVY EQUIPMENT 26 - BICYCLE
 5 - CARGO VAN 11 - ALL TERRAIN VEHICLE (ATV/UTV) 16 - FARM EQUIPMENT 22 - ANIMAL WITH RIDER OR ANIMAL-DRAWN VEHICLE 27 - TRAIN
 6 - VAN (19-15 SEATS) 17 - MOTORHOME 99 - UNKNOWN OR HIT/SKIP

OF TRAILING UNITS
0

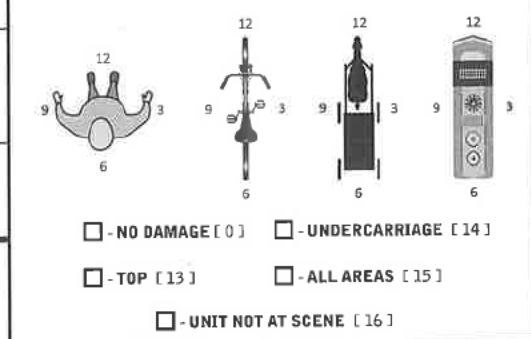

WAS VEHICLE OPERATING IN AUTONOMOUS MODE WHEN CRASH OCCURRED?
2 1 - YES 2 - NO 9 - OTHER / UNKNOWN
AUTONOMOUS MODE LEVEL
0
 0 - NO AUTOMATION 3 - CONDITIONAL AUTOMATION 9 - UNKNOWN
 1 - DRIVER ASSISTANCE 4 - HIGH AUTOMATION
 2 - PARTIAL AUTOMATION 5 - FULL AUTOMATION

SPECIAL FUNCTION
01
 1 - NONE 6 - BUS - CHARTER/TOUR 11 - FIRE 16 - FARM 21 - MAIL CARRIER
 2 - TAXI 7 - BUS - INTERCITY 12 - MILITARY 17 - MOWING 99 - OTHER / UNKNOWN
 3 - ELECTRONIC RIDE SHARING 8 - BUS - SHUTTLE 13 - POLICE 18 - SNOW REMOVAL
 4 - SCHOOL TRANSPORT 9 - BUS - OTHER 14 - PUBLIC UTILITY 19 - TOWING
 5 - BUS - TRANSIT/COMMUTER 10 - AMBULANCE 15 - CONSTRUCTION EQUIPMENT 20 - SAFETY SERVICE PATROL

CARGO BODY TYPE
01
 1 - NO CARGO BODY TYPE / NOT APPLICABLE 3 - VEHICLE TOWING ANOTHER MOTOR VEHICLE 5 - INTERMODAL CONTAINER CHASSIS 8 - POLE 12 - CONCRETE MIXER
 2 - BUS 4 - LOGGING 6 - CARGO VAN/ENCLOSED BOX 9 - CARGO TANK 13 - AUTO TRANSPORTER
 7 - GRAINCHIPS/GRAVEL 10 - FLAT BED 14 - GARBAGE/REFUSE 19 - OTHER / UNKNOWN
 11 - DUMP

VEHICLE DEFECTS
01
 1 - TURN SIGNALS 4 - BRAKES 7 - WORN OR SLICK TIRES 9 - MOTOR TROUBLE 99 - OTHER / UNKNOWN
 2 - HEAD LAMPS 5 - STEERING 8 - TRAILER EQUIPMENT DEFECTIVE 10 - DISABLED FROM PRIOR ACCIDENT
 3 - TAIL LAMPS 6 - TIRE BLOWOUT

NON-MOTORIST LOCATION AT IMPACT
01
 1 - INTERSECTION - MARKED CROSSWALK 3 - INTERSECTION - OTHER CROSSWALK 6 - BICYCLE LANE 9 - MEDIAN/CROSSING ISLAND 12 - FIRST RESPONDER AT INCIDENT SCENE
 2 - INTERSECTION - UNMARKED CROSSWALK 4 - MIDBLOCK - MARKED CROSSWALK 7 - SHOULDER / ROADSIDE 10 - DRIVEWAY ACCESS 99 - OTHER / UNKNOWN
 5 - TRAVEL LANE - OTHER LOCATION 8 - SIDEWALK 11 - SHARED USE PATHS OR TRAILS

ACTION
4
 1 - NON-CONTACT 1 - STRAIGHT AHEAD 7 - MAKING U-TURN 13 - NEGOTIATING A CURVE OR LEAVING VEHICLE 18 - APPROACHING OR LEAVING VEHICLE
 2 - NON-COLLISION 2 - BACKING 8 - ENTERING TRAFFIC LANE 14 - ENTERING OR CROSSING SPECIFIED LOCATION 19 - STANDING
 3 - STRIKING 3 - CHANGING LANES 9 - LEAVING TRAFFIC LANE 15 - WALKING, RUNNING, JOGGING, PLAYING 20 - OTHER NON-MOTORIST
 4 - STRUCK PRE-CRASH ACTIONS 4 - OVERTAKING/PASSING 10 - PARKED 16 - WORKING 21 - STANDING OUTSIDE DISABLED VEHICLE
 5 - BOTH STRIKING & STRUCK 5 - MAKING RIGHT TURN 11 - SLOWING OR STOPPED IN TRAFFIC 17 - PUSHING VEHICLE 99 - OTHER / UNKNOWN
 9 - OTHER / UNKNOWN 6 - MAKING LEFT TURN 12 - DRIVERLESS

INITIAL POINT OF CONTACT
08
 0 - NO DAMAGE 14 - UNDERCARRIAGE
 1-12 - REFER TO UNIT DIAGRAM 15 - VEHICLE NOT AT SCENE
 13 - TOP 99 - UNKNOWN

CONTRIBUTING CIRCUMSTANCES
01
 1 - NONE 7 - LEFT OF CENTER 13 - IMPROPER START FROM A PARKED POSITION 17 - VISION OBSTRUCTION 21 - LYING IN ROADWAY
 2 - FAILURE TO YIELD 8 - FOLLOWING TOO CLOSE / ACDA 14 - STOPPED OR PARKED ILLEGALLY 18 - OPERATING DEFECTIVE EQUIPMENT 22 - NOT DISCERNIBLE
 3 - RAN RED LIGHT 9 - IMPROPER LANE CHANGE 15 - SWERVING TO AVOID 19 - LOAD SHIFTING/FALLING/ SPILLING 23 - OPENING DOOR INTO ROADWAY
 4 - RAN STOP SIGN 10 - IMPROPER PASSING 16 - WRONG WAY 20 - IMPROPER CROSSING 99 - OTHER IMPROPER ACTION
 5 - UNSAFE SPEED 11 - DROVE OFF ROAD 17 - VISION OBSTRUCTION 21 - LYING IN ROADWAY
 6 - IMPROPER TURN 12 - IMPROPER BACKING

TRAFFIC
TRAFFICWAY FLOW
2 1 - ONE-WAY 2 - TWO-WAY
TRAFFIC CONTROL
6 1 - ROUNDABOUT 4 - STOP SIGN
 2 - SIGNAL 5 - YIELD SIGN
 3 - FLASHER 6 - NO CONTROL
OF THROUGH LANES ON ROAD
2
RAIL GRADE CROSSING
1 1 - NOT INVOLVED
 2 - INVOLVED-ACTIVE CROSSING
 3 - INVOLVED-PASSIVE CROSSING

SEQUENCE OF EVENTS
1 **20**
 1 - OVERTURN/ROLLOVER 6 - EQUIPMENT FAILURE 11 - CROSS CENTERLINE - OPPOSITE DIRECTION OF TRAVEL 16 - RAILWAY VEHICLE 22 - WORK ZONE MAINTENANCE EQUIPMENT
 2 - FIRE/EXPLOSION 7 - SEPARATION OF UNITS 12 - DOWNHILL RUNAWAY 17 - ANIMAL - FARM 23 - STRUCK BY FALLING, SHIFTING CARGO OR ANYTHING SET IN MOTION BY A MOTOR VEHICLE
 3 - IMMERSION 8 - RAN OFF ROAD RIGHT 13 - OTHER NON-COLLISION 18 - ANIMAL - DEER 24 - OTHER MOVABLE OBJECT
 4 - JACKKNIFE 9 - RAN OFF ROAD LEFT 14 - PEDESTRIAN 19 - ANIMAL - OTHER
 5 - CARGO / EQUIPMENT LOSS OR SHIFT 10 - CROSS MEDIAN 15 - PEDALCYCLE 20 - MOTOR VEHICLE IN TRANSPORT
 6 - IMPROPER TURN 12 - IMPROPER BACKING

UNIT / NON-MOTORIST DIRECTION
1 **4**
 FROM **1** TO **4**
 1 - NORTH 5 - NORTHEAST
 2 - SOUTH 6 - NORTHWEST
 3 - EAST 7 - SOUTHEAST
 4 - WEST 8 - SOUTHWEST
 9 - OTHER / UNKNOWN

COLLISION WITH FIXED OBJECT - STRUCK
1
 25 - IMPACT ATTENUATOR / CRASH CUSHION 31 - GUARDRAIL END 37 - TRAFFIC SIGN POST 43 - CURB 50 - WORK ZONE MAINTENANCE EQUIPMENT
 26 - BRIDGE OVERHEAD STRUCTURE 32 - PORTABLE BARRIER 38 - OVERHEAD SIGN POST 44 - DITCH 51 - WALL
 27 - BRIDGE PIER OR ABUTMENT 33 - MEDIAN CABLE BARRIER 39 - LIGHT / LUMINARIES SUPPORT 45 - EMBANKMENT 52 - BUILDING
 28 - BRIDGE PARAPET 34 - MEDIAN GUARDRAIL BARRIER 40 - UTILITY POLE 46 - FENCE 53 - TUNNEL
 29 - BRIDGE RAIL 35 - MEDIAN CONCRETE BARRIER 41 - OTHER POST, POLE OR SUPPORT 47 - MAILBOX 54 - OTHER FIXED OBJECT
 30 - GUARDRAIL FACE 36 - MEDIAN OTHER BARRIER 42 - CULVERT 48 - TREE 99 - OTHER / UNKNOWN
 49 - FIRE HYDRANT

FIRST HARMFUL EVENT **1** **MOST HARMFUL EVENT** **1**

UNIT SPEED
10
POSTED SPEED
25
DETECTED SPEED
1 1 - STATED / ESTIMATED SPEED
 2 - CALCULATED / EDR
 3 - UNDETERMINED



MOTORIST / Non-MOTORIST

LOCAL REPORT NUMBER
24-090-0364

UNIT # 01	NAME: LAST, FIRST, MIDDLE Reynolds, Carson, Cody	DATE OF BIRTH 05.13.2005	AGE 18	GENDER M
ADDRESS: STREET, CITY, STATE, ZIP 10609 Churchill Dr. Powell, OH 43065		CONTACT PHONE - INCLUDE AREA CODE [REDACTED]		
INJURIES 5	INJURED TAKEN BY 1	EMS AGENCY (NAME)	INJURED TAKEN TO: MEDICAL FACILITY (NAME, CITY)	SAFETY EQUIPMENT USED 99
<input type="checkbox"/> DOT-COMPLIANT MC HELMET	SEATING POSITION 01	AIR BAG USAGE	EJECTION	TRAPPED
OL STATE	OPERATOR LICENSE NUMBER	OFFENSE CHARGED	LOCAL CODE	OFFENSE DESCRIPTION
OL CLASS 4	ENDORSEMENT	RESTRICTION	DRIVER DISTRACTED BY 9	ALCOHOL / DRUG SUSPECTED <input type="checkbox"/> ALCOHOL <input type="checkbox"/> MARIJUANA <input type="checkbox"/> OTHER DRUG
CONDITION 9	ALCOHOL TEST		DRUG TEST(S)	
STATUS	TYPE	VALUE	STATUS	TYPE
1	1		1	1

UNIT # 02	NAME: LAST, FIRST, MIDDLE Taylor, Theodore, A.	DATE OF BIRTH 1.2.11.2001	AGE 22	GENDER M
ADDRESS: STREET, CITY, STATE, ZIP 6149 Saint Regis Dr. Cincinnati, OH 45236		CONTACT PHONE - INCLUDE AREA CODE [REDACTED]		
INJURIES 5	INJURED TAKEN BY 1	EMS AGENCY (NAME)	INJURED TAKEN TO: MEDICAL FACILITY (NAME, CITY)	SAFETY EQUIPMENT USED 99
<input type="checkbox"/> DOT-COMPLIANT MC HELMET	SEATING POSITION 01	AIR BAG USAGE	EJECTION	TRAPPED
OL STATE	OPERATOR LICENSE NUMBER	OFFENSE CHARGED	LOCAL CODE	OFFENSE DESCRIPTION
OL CLASS 4	ENDORSEMENT	RESTRICTION	DRIVER DISTRACTED BY 9	ALCOHOL / DRUG SUSPECTED <input type="checkbox"/> ALCOHOL <input type="checkbox"/> MARIJUANA <input type="checkbox"/> OTHER DRUG
CONDITION 9	ALCOHOL TEST		DRUG TEST(S)	
STATUS	TYPE	VALUE	STATUS	TYPE
1	1		1	1

UNIT #	NAME: LAST, FIRST, MIDDLE	DATE OF BIRTH	AGE	GENDER
ADDRESS: STREET, CITY, STATE, ZIP		CONTACT PHONE - INCLUDE AREA CODE		
INJURIES	INJURED TAKEN BY	EMS AGENCY (NAME)	INJURED TAKEN TO: MEDICAL FACILITY (NAME, CITY)	SAFETY EQUIPMENT USED
<input type="checkbox"/> DOT-COMPLIANT MC HELMET	SEATING POSITION	AIR BAG USAGE	EJECTION	TRAPPED
OL STATE	OPERATOR LICENSE NUMBER	OFFENSE CHARGED	LOCAL CODE	OFFENSE DESCRIPTION
OL CLASS	ENDORSEMENT	RESTRICTION	DRIVER DISTRACTED BY	ALCOHOL / DRUG SUSPECTED
CONDITION	ALCOHOL TEST		DRUG TEST(S)	
STATUS	TYPE	VALUE	STATUS	TYPE

INJURIES	SEATING POSITION	AIR BAG	OL CLASS	OL RESTRICTION(S)	DRIVER DISTRACTION	TEST STATUS
1 - FATAL	1 - FRONT - LEFT SIDE (MOTORCYCLE DRIVER)	1 - NOT DEPLOYED	1 - CLASS A	1 - ALCOHOL INTERLOCK DEVICE	1 - NOT DISTRACTED	1 - NONE GIVEN
2 - SUSPECTED SERIOUS INJURY	2 - FRONT - MIDDLE	2 - DEPLOYED FRONT	2 - CLASS B	2 - CDL INTRASTATE ONLY	2 - MANUALLY OPERATING AN ELECTRONIC COMMUNICATION DEVICE (TEXTING, TYPING, DIALING)	2 - TEST REFUSED
3 - SUSPECTED MINOR INJURY	3 - FRONT - RIGHT SIDE	3 - DEPLOYED SIDE	3 - CLASS C	3 - CORRECTIVE LENSES	3 - TALKING ON HANDS-FREE COMMUNICATION DEVICE	3 - TEST GIVEN, CONTAMINATED SAMPLE / UNUSABLE
4 - POSSIBLE INJURY	4 - SECOND - LEFT SIDE (MOTORCYCLE PASSENGER)	4 - DEPLOYED BOTH FRONT / SIDE	4 - REGULAR CLASS (OHIO = D)	4 - FARM WAIVER	4 - TALKING ON HAND-HELD COMMUNICATION DEVICE	4 - TEST GIVEN, RESULTS KNOWN
5 - NO APPARENT INJURY	5 - SECOND - MIDDLE	5 - NOT APPLICABLE	5 - M/C MOPED ONLY	5 - EXCEPT CLASS A BUS	5 - OTHER ACTIVITY WITH AN ELECTRONIC DEVICE	5 - TEST GIVEN, RESULTS UNKNOWN
INJURED TAKEN BY	6 - SECOND - RIGHT SIDE	9 - DEPLOYMENT UNKNOWN	6 - NO VALID DL	6 - EXCEPT CLASS A & CLASS B BUS	6 - PASSENGER	ALCOHOL TEST TYPE
1 - NOT TRANSPORTED / TREATED AT SCENE	7 - THIRD - LEFT SIDE (MOTORCYCLE SIDE CAR)	EJECTION	OL ENDORSEMENT	7 - EXCEPT TRACTOR-TRAILER	7 - OTHER DISTRACTION INSIDE THE VEHICLE	1 - NONE
2 - EMS	8 - THIRD - MIDDLE	1 - NOT EJECTED	H - HAZMAT	8 - INTERMEDIATE LICENSE RESTRICTIONS	8 - OTHER DISTRACTION OUTSIDE THE VEHICLE	2 - BLOOD
3 - POLICE	9 - THIRD - RIGHT SIDE	2 - PARTIALLY EJECTED	M - MOTORCYCLE	9 - LEARNER'S PERMIT RESTRICTIONS	9 - OTHER / UNKNOWN	3 - URINE
9 - OTHER / UNKNOWN	10 - SLEEPER SECTION OF TRUCK CAB	3 - TOTALLY EJECTED	P - PASSENGER	10 - LIMITED TO DAYLIGHT ONLY	CONDITION	4 - BREATH
SAFETY EQUIPMENT	11 - PASSENGER IN OTHER ENCLOSED CARGO AREA (NON-TRAILING UNIT, BUS, PICK-UP WITH CAP)	4 - NOT APPLICABLE	N - TANKER	11 - LIMITED TO EMPLOYMENT	1 - APPARENTLY NORMAL	5 - OTHER
1 - NONE USED	12 - PASSENGER IN UNENCLOSED CARGO AREA	TRAPPED	Q - MOTOR SCOOTER	12 - LIMITED - OTHER	2 - PHYSICAL IMPAIRMENT	DRUG TEST TYPE
2 - SHOULDER BELT ONLY USED	13 - TRAILING UNIT	1 - NOT TRAPPED	R - THREE-WHEEL MOTORCYCLE	13 - MECHANICAL DEVICES (SPECIAL BRAKES, HAND CONTROLS, OR OTHER ADAPTIVE DEVICES)	3 - EMOTIONAL (E.G., DEPRESSED, ANGRY, DISTURBED)	1 - NONE
3 - LAP BELT ONLY USED	14 - RIDING ON VEHICLE EXTERIOR (NON-TRAILING UNIT)	2 - EXTRICATED BY MECHANICAL MEANS	S - SCHOOL BUS	14 - MILITARY VEHICLES ONLY	4 - ILLNESS	2 - BLOOD
4 - SHOULDER & LAP BELT USED	15 - NON-MOTORIST	3 - FREED BY NON-MECHANICAL MEANS	T - DOUBLE & TRIPLE TRAILERS	15 - MOTOR VEHICLES WITHOUT AIR BRAKES	5 - FELL ASLEEP, FAINTED, FATIGUED, ETC.	3 - URINE
5 - CHILD RESTRAINT SYSTEM - FORWARD FACING	99 - OTHER / UNKNOWN	GENDER	X - TANKER / HAZMAT	16 - OUTSIDE MIRROR	6 - UNDER THE INFLUENCE OF MEDICATIONS / DRUGS / ALCOHOL	4 - OTHER
6 - CHILD RESTRAINT SYSTEM - REAR FACING		F - FEMALE		17 - PROSTHETIC AID	9 - OTHER / UNKNOWN	DRUG TEST RESULT(S)
7 - BOOSTER SEAT		M - MALE		18 - OTHER		1 - AMPHETAMINES
8 - HELMET USED		U - OTHER / UNKNOWN				2 - BARBITURATES
9 - PROTECTIVE PADS USED (ELBOW, KNEES, ETC.)						3 - BENZODIAZEPINES
10 - REFLECTIVE CLOTHING						4 - CANNABINOIDS
11 - LIGHTING - PEDESTRIAN / BICYCLE ONLY						5 - COCAINE
99 - OTHER / UNKNOWN						6 - OPIATES / OPIOIDS
						7 - OTHER
						8 - NEGATIVE RESULTS



OCCUPANT / WITNESS ADDENDUM

LOCAL REPORT NUMBER
24-OPP-0364

OCCUPANT	UNIT #	NAME: LAST, FIRST, MIDDLE			DATE OF BIRTH	AGE	GENDER		
	1	Lishing, Benjamin, Patrick			03-15-2003	21	M		
ADDRESS: STREET, CITY, STATE, ZIP				CONTACT PHONE - INCLUDE AREA CODE					
10009 Edgewater Dr. Cleveland, OH 44102				[REDACTED]					
INJURIES	INJURED TAKEN BY	EMS AGENCY (NAME)	INJURED TAKEN TO: MEDICAL FACILITY (NAME, CITY)	SAFETY EQUIPMENT USED	DOT-COMPLIANT MC HELMET	SEATING POSITION	AIR BAG USAGE	EJECTION	TRAPPED
5	1			99	<input type="checkbox"/>	99	01	1	1

OCCUPANT	UNIT #	NAME: LAST, FIRST, MIDDLE			DATE OF BIRTH	AGE	GENDER		
	1	Jones, Cole, Reber			12-10-2002	21	M		
ADDRESS: STREET, CITY, STATE, ZIP				CONTACT PHONE - INCLUDE AREA CODE					
5227 Hillgrove Dr. Lorain, OH 44053				[REDACTED]					
INJURIES	INJURED TAKEN BY	EMS AGENCY (NAME)	INJURED TAKEN TO: MEDICAL FACILITY (NAME, CITY)	SAFETY EQUIPMENT USED	DOT-COMPLIANT MC HELMET	SEATING POSITION	AIR BAG USAGE	EJECTION	TRAPPED
5	1			99	<input type="checkbox"/>	99	01	1	1

OCCUPANT	UNIT #	NAME: LAST, FIRST, MIDDLE			DATE OF BIRTH	AGE	GENDER		
ADDRESS: STREET, CITY, STATE, ZIP				CONTACT PHONE - INCLUDE AREA CODE					
INJURIES	INJURED TAKEN BY	EMS AGENCY (NAME)	INJURED TAKEN TO: MEDICAL FACILITY (NAME, CITY)	SAFETY EQUIPMENT USED	DOT-COMPLIANT MC HELMET	SEATING POSITION	AIR BAG USAGE	EJECTION	TRAPPED
					<input type="checkbox"/>				

OCCUPANT	UNIT #	NAME: LAST, FIRST, MIDDLE			DATE OF BIRTH	AGE	GENDER		
ADDRESS: STREET, CITY, STATE, ZIP				CONTACT PHONE - INCLUDE AREA CODE					
INJURIES	INJURED TAKEN BY	EMS AGENCY (NAME)	INJURED TAKEN TO: MEDICAL FACILITY (NAME, CITY)	SAFETY EQUIPMENT USED	DOT-COMPLIANT MC HELMET	SEATING POSITION	AIR BAG USAGE	EJECTION	TRAPPED
					<input type="checkbox"/>				

INJURIES	SAFETY EQUIPMENT USED	SEATING POSITION	AIR BAG USAGE
1 - FATAL 2 - SUSPECTED SERIOUS INJURY 3 - SUSPECTED MINOR INJURY 4 - POSSIBLE INJURY 5 - NO APPARENT INJURY	1 - NONE USED - VEHICLE OCCUPANT 2 - SHOULDER BELT ONLY USED 3 - LAP BELT ONLY USED 4 - SHOULDER & LAP BELT USED 5 - CHILD RESTRAINT SYSTEM - FORWARD FACING 6 - CHILD RESTRAINT SYSTEM - REAR FACING 7 - BOOSTER SEAT 8 - HELMET USED 9 - PROTECTIVE PADS USED (ELBOW, KNEES, ETC.) 10 - REFLECTIVE CLOTHING 11 - LIGHTING - PEDESTRIAN / BICYCLE ONLY 99 - OTHER / UNKNOWN	1 - FRONT - LEFT SIDE (MOTORCYCLE DRIVER) 2 - FRONT - MIDDLE 3 - FRONT - RIGHT SIDE 4 - SECOND - LEFT SIDE (MOTORCYCLE PASSENGER) 5 - SECOND - MIDDLE 6 - SECOND - RIGHT SIDE 7 - THIRD - LEFT SIDE (MOTORCYCLE SIDE CAR) 8 - THIRD - MIDDLE 9 - THIRD - RIGHT SIDE 10 - SLEEPER SECTION OF TRUCK CAB 11 - PASSENGER IN OTHER ENCLOSED CARGO AREA (NON-TRAILING UNIT, BUS, PICK-UP WITH CAP) 12 - PASSENGER IN UNENCLOSED CARGO AREA 13 - TRAILING UNIT 14 - RIDING ON VEHICLE EXTERIOR (NON-TRAILING UNIT) 15 - NON-MOTORIST 99 - OTHER / UNKNOWN	1 - NOT DEPLOYED 2 - DEPLOYED FRONT 3 - DEPLOYED SIDE 4 - DEPLOYED BOTH FRONT/SIDE 5 - NOT APPLICABLE 9 - DEPLOYMENT UNKNOWN EJECTION 1 - NOT EJECTED 2 - PARTIALLY EJECTED 3 - TOTALLY EJECTED 4 - NOT APPLICABLE TRAPPED 1 - NOT TRAPPED 2 - EXTRICATED BY MECHANICAL MEANS 3 - FREED BY NON-MECHANICAL MEANS

WITNESS	NAME: LAST, FIRST, MIDDLE	DATE OF BIRTH	AGE	GENDER
ADDRESS: STREET, CITY, STATE, ZIP		CONTACT PHONE - INCLUDE AREA CODE		

WITNESS	NAME: LAST, FIRST, MIDDLE	DATE OF BIRTH	AGE	GENDER
ADDRESS: STREET, CITY, STATE, ZIP		CONTACT PHONE - INCLUDE AREA CODE		

WITNESS	NAME: LAST, FIRST, MIDDLE	DATE OF BIRTH	AGE	GENDER
ADDRESS: STREET, CITY, STATE, ZIP		CONTACT PHONE - INCLUDE AREA CODE		